

PLAYGUARD[®]

SAFETY SURFACING



THE ONLY 15 YEAR WARRANTY IN THE INDUSTRY
INCLUDES IMPACT ATTENUATION TO ASTM F1292



You Can't + All Be T

Always There To Catch Them



Who We Are

PlayGuard 24-inch by 24-inch playground tiles safely cushion the impact of a fall to reduce the risk of serious injury to both outdoor and indoor play areas! Ecore, a company that transforms reclaimed waste into unique surfaces that makes people's lives better, manufactures all PlayGuard products from recycled rubber in the U.S.A.

Any design or color can be implemented with PlayGuard's custom color and logo capabilities.

Main product lines:

- Safari Ultra: basic = black + color
- Carnival Ultra: bold/energetic colors
- Pigmented: earth-tone hues

PlayGuard features easy installation and maintenance and offers the industry's only 15-year warranty!

Ecore reinforces its commitment to safety by being one of the few playground surfacing manufacturers to take its product through the rigorous process of becoming IPEMA™ certified. PlayGuard Safety Surfacing meets the ASTM F1292-13 standard specification for impact attenuation for falls and guidelines established by the U.S. Consumer

Product Safety Commission. PlayGuard tiles also meet accessibility requirements of the Americans with Disabilities Act and are certified to ASTM F1951-09b, a determination of accessibility of surface systems under and around playground equipment.

*PlayGuard pigmented tiles are not recommended for certain indoor uses. Please contact your distributor for details.



Characteristics

- 24" x 24" modular tiles in four thicknesses for choices in impact resistance and cost
- Factory molded to ensure consistent fall height protection and uniform appearance
- Patented, pre-manufactured colorful Ultra wear layer (1", 2-1/2", and 4-1/4")
- Meets 2', 6', 8', and 10' critical fall height requirements per ASTM F1292-13 and is CPSC compliant
- Slip resistant for wet or dry surfaces
- Resilient, comfortable surface encourages play
- Tiles won't crack, eliminating unsightly surface repairs
- Will not shift or displace during play
- Meets ADA standards
- Extremely durable for low life-cycle costs
- Easy to clean, low-maintenance surface
- Unlikely to conceal sharp or potentially harmful objects
- Individual tiles can be removed and replaced if damaged
- Custom colors, logos, and designs available for PlayGuard Ultra
- Made in the U.S.A. from the highest quality recycled rubber
- 15 year warranty on all products

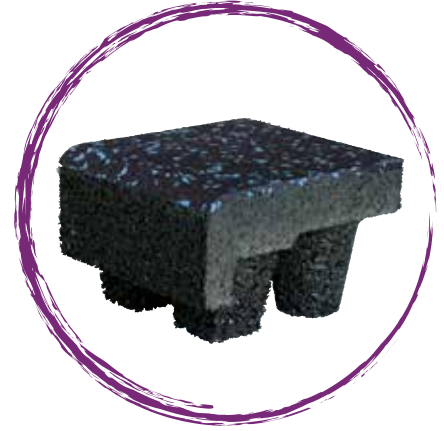

Applications

- Playgrounds
- Rooftops
- Patios
- Recreation spaces
- Daycare & after-school activity grounds
- Rehabilitation centers
- Schools



Sustainability

Creating Sustainable Environments

Ecore is the largest user of scrap tire rubber in the U.S.A., converting more than 65 million pounds of tires annually into recycled rubber flooring. With our state of the art equipment, experienced staff, and 100 million pound capacity, Ecore is uniquely capable of producing the cleanest, most consistent, and highest quality material available in the market place.



by SCS Certified

Floor Score

Indoor PlayGuard applications are FloorScore certified for compliance with rigorous indoor air quality emission requirements.



CHPS

PlayGuard meets the Collaborative for High Performance Schools (CHPS) criteria, the state of Washington standard for indoor air quality, and supports ASTM 2129-05 Sustainability Assessment.



LEED

PlayGuard can contribute toward earning up to 8 LEED points. For information on how PlayGuard can contribute to LEED points please visit PlayGuardSafetySurfacing.com.



Carnival Ultra



Cherry Blast 2 PG61A



Caramel Corn 2 PG66A

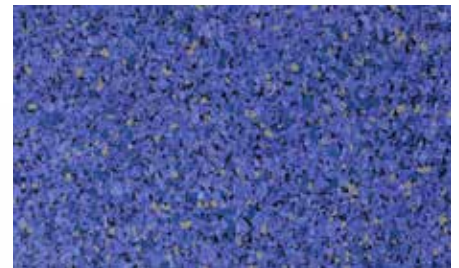

Grape Slushie PG78



Used in combination or as single color accents, the wear layer colors of the Carnival Ultra line create bright and engaging atmospheres that beg for participation and activity. This collection's vivid patterns bring design themes to life and transform playgrounds into lively community attractions. Carnival Ultra tiles are manufactured with proprietary processes that mold a dense recycled rubber and EPDM wear layer, which is 3mm thick, to a footed recycled rubber base.

*Actual sample and final product may vary from color swatches shown in this catalog.

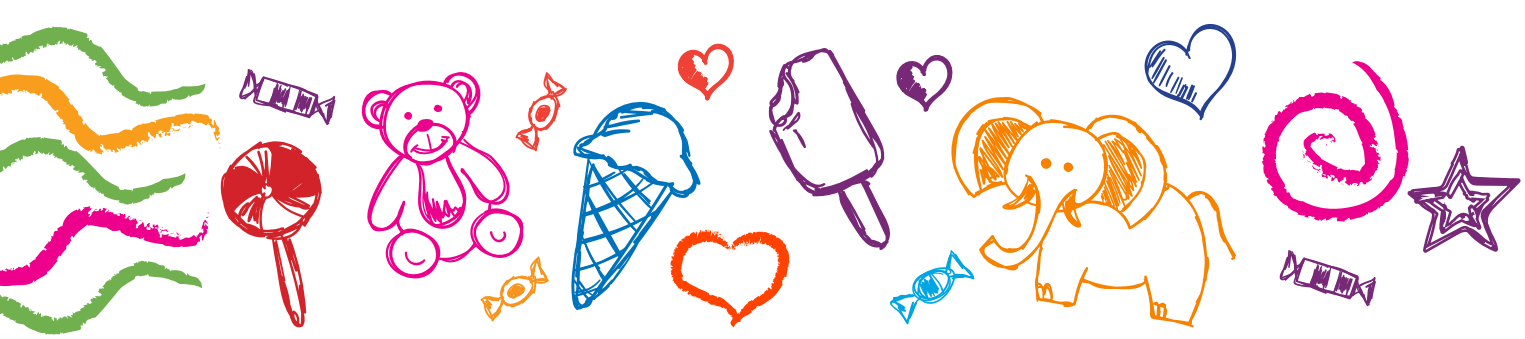

Blueberry Pie 2 PG62A



Sour Apple 2 PG63A



Rock Candy 2 PG65A

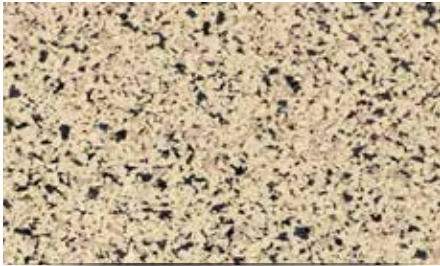

Funnel Cake 2 PG67A

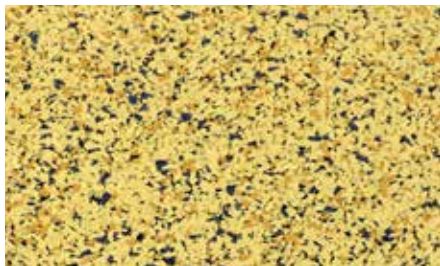

Lemonade PG76

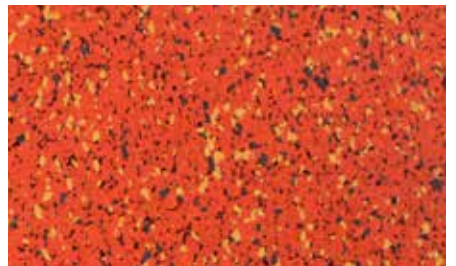

Orangesicle PG77



Specifications

Tiles: 24" x 24"
 Thicknesses: 1", 2.5", & 4.25"

Recommended Accessory Colors

PG61B PG62B PG63B PG65B PG66B
 PG67B PG76A PG77A PG78A



Safari Ultra



PlayGuard's Safari Ultra line is ideal for creating subtle color that brightens an environment without creating a bold design statement. Safari Ultra tiles are manufactured with proprietary processes that mold a dense recycled rubber and EPDM wear layer, which is 3mm thick, to a footed recycled rubber base.



Midnight PG50

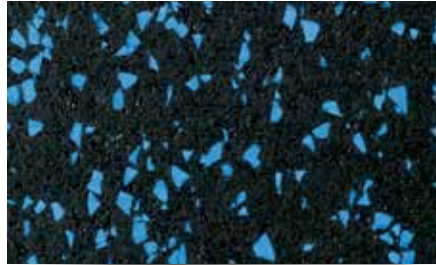

Rain Drops PG51

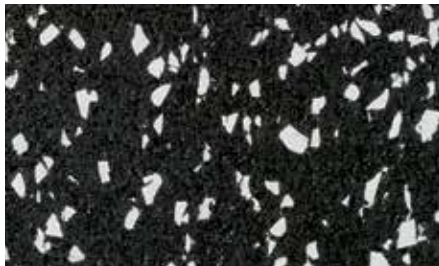

Zappy Zebra PG52



Cheetah Gold PG56

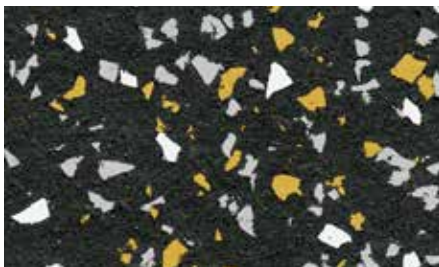

Bumble Bee PG72

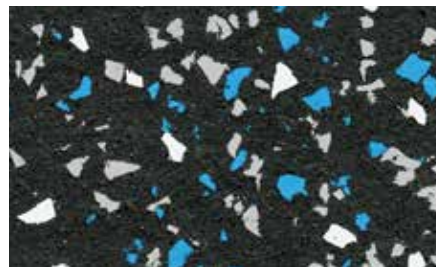

Blue Skies PG73

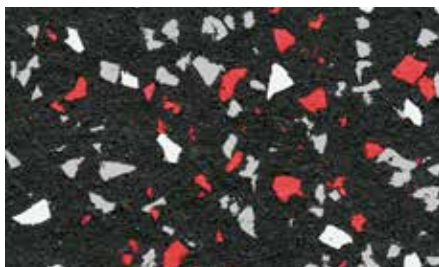

Ladybug PG74

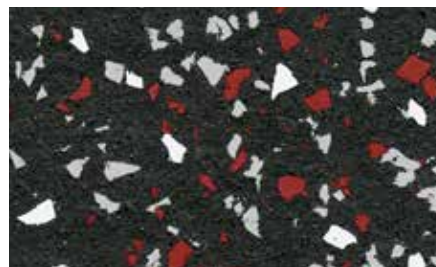

Red Fox PG75



*Actual sample and final product may vary from color swatches shown in this catalog.

Specifications

Tiles: 24" x 24"
Thicknesses: 1", 2.5", & 4.25"

Recommended Accessory Colors

PG40A



Pigmented

If color isn't a primary consideration, budgets are tight, or simplistic design is the focus, Pigmented tiles are the ideal solution! Manufactured without an EPDM wear layer, the earth-tone hues of the Pigmented collection are produced by evenly distributing pigment throughout the rubber tile.

Custom color and logo options are not available for pigmented tiles.



Black PG40 (Non-Pigmented)



Grey PG41

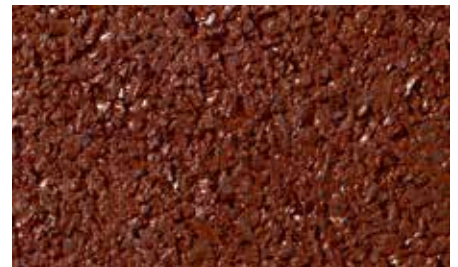

Red PG42



Green PG43

* Pigmented tiles are **not** recommended for indoor use.

Specifications

Tiles: 24" x 24"
Thicknesses: 1", 2.5", & 3.75"

Recommended Accessory Colors

PG40A PG41A PG42A PG43A

Swing Mats



PlayGuard Swing Mats are loose lay and can easily be installed under swing sets and at the feet of sliding boards. Swing Mats do not carry a fall height rating and are only recommended to help prevent the spread of wood mulch, pea gravel, or rubber crumb. Available in black only.

Specifications

Tiles: 36" x 36"
Thicknesses: 1.5"



Accessories

1" Carnival Ultra, Safari Ultra, & Pigmented

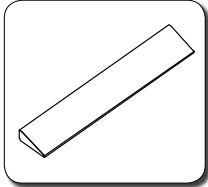

Reducer
48" x 4" x 1"

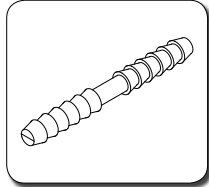

Dowel Pin
3.125" x 1/4"

2½" Carnival Ultra, Safari Ultra, & Pigmented

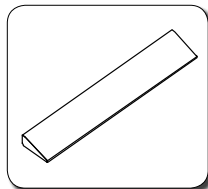

Reducer
48" x 8" x 2-1/2"

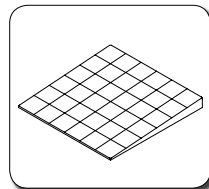

ADA Access Ramp
24" x 24" x 2-1/2" (2)

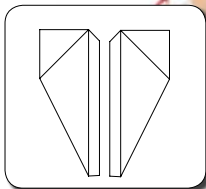

L/R Side Reducer for ADA Access Ramp
24" x 8" x 2-1/2"

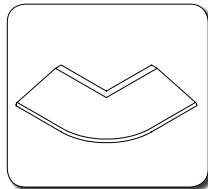

Outside 90 Corner
Reducer
16" x 8" x 2-1/2"

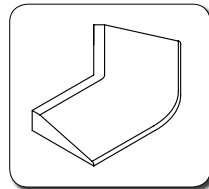

Outside 45 Corner
Reducer
16" x 8" x 2-1/2"

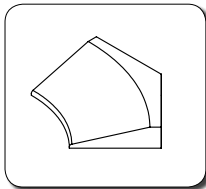

Inside 45 Corner
Reducer
12" x 8" x 2-1/2"

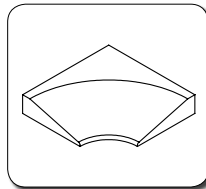

Inside 90 Corner
Reducer
12" x 8" x 2-1/2"

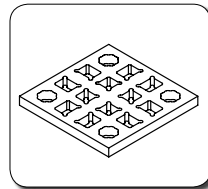

Quad Blok Connector
8" x 8" x 17 mm

4¼" Carnival Ultra, Safari Ultra

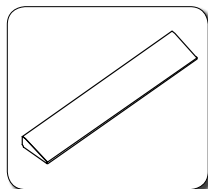

Reducer
48" x 12" x 4-1/4"

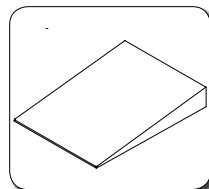

ADA Access Ramp
48" x 19-3/4" (2)
Custom order only

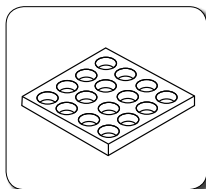

Large Quad Blok
Connector
8.75" x 8.75" x 19mm

3¾" Pigmented

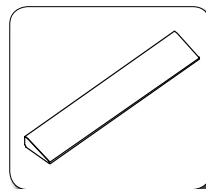

Reducer
48" x 12" x 3-3/4"

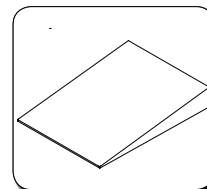

ADA Access Ramp
48" x 19-3/4" (2)
Custom order only

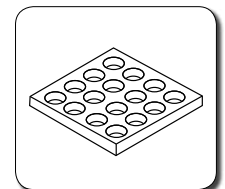

Large Quad Blok
Connector
8.75" x 8.75" x 19mm

Accessories are not manufactured with an Ultra wear layer. The EPDM colored granules or pigments are homogeneously mixed throughout to produce coordinated designs for all Ultra and Pigmented colors.

Accessory Colors



12 | 13 PLAYGUARD SAFETY SURFACING



Black PG40A



Grey PG41A



Red PG42A



Green PG43A

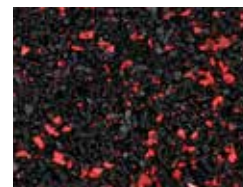

Cherry Blast 2 PG61B

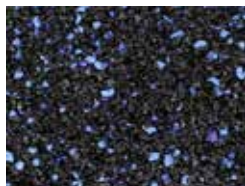

Blueberry Pie 2 PG62B

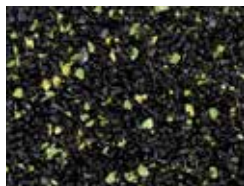

Sour Apple 2 PG63B



Rock Candy 2 PG65B



Caramel Corn 2 PG66B



Funnel Cake 2 PG67B

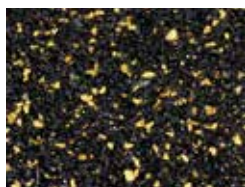

Lemonade PG76A

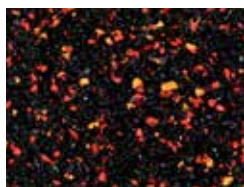

Orangesicle PG77A

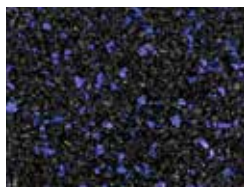

Grape Slushie PG78A



For the most up to date colors please visit playguardsurfacing.com.
Actual sample and final product may vary from color swatches shown in this catalog.

Custom Colors



1102 Eggshell



1202 Light Grey



1204 Medium Grey



1205 Greige



1206 Warm Grey



1208 Clay Grey



1210 Dark Grey



1306 Sand



1403 Sky Blue



1407 Midnight Blue



1410 Retro Deep Aqua



1412 Cobalt



1503 Purple



1509 Blue Purple



1610 Army Green



1620 True Lime



With PlayGuard's custom color program, there are no limitations to the imagination. It's easy to find the color blend that is right for any project by selecting colors from our EPDM palette shown here.



1622 Shadow Lime



1624 Veggie



1630 Olive



1703 Yellow



1708 Gold



1806 Bright Red



1808 Brick Red



1812 Fuchsia



1816 Shadow Red



1818 Red Orange



1904 Orange*



1908 Melon



2100 Dark Camel



2105 Deep Taupe



2110 Mid Taupe



2115 Mid Camel



2120 Tan Sage



2125 Dark Chocolate



2170 Brown

*1904 Orange is for indoor application only.



For the most up to date colors please visit playguardsurfacing.com.
Actual sample and final product may vary from color swatches shown in this catalog.

Custom Designs

**If it can be imagined,
PlayGuard can create it.**

Create playful patterns using distinctly colored tiles or make a bold statement with custom designs created to complement any project's theme. Custom logos and designs can be created with any combination of Carnival Ultra, Safari Ultra, or custom colors and are manufactured as a part of the tile's wear layer for long-lasting patterns that don't flake, chip, or peel.





Live to Play

PlayGuard Safety Surfacing's Live to Play Program is a creative way to bring active play to your playground through designs in the surface. Through our patented tile technology, we are able to cut inlaid water-jet designs directly into the surface of the tile using precise detail that is not currently available through traditional tile and poured-in-place products. You may choose from our Live to Play portfolio of existing inspirational ideas designed to spark your imagination, or work with PlayGuard and our partners to design your own custom surface.

When choosing directly from our Live to Play product portfolio, all artwork, proofing, and pricing has already been done in advance and allows you to expedite your bidding process, while still achieving a truly custom look.

Options

- Foursquare
- Hopscotch: Simple
- Hopscotch: Extreme
- Checkers Board
- Baseball
- Basketball
- Football
- Footprints
- Soccer Ball
- Tennis Ball
- Runner
- 50 States



Benefits

- Features a patented, water jet cut tile system
- 15 year warranty
- Standard and custom graphic options
- Endless color options
- Unsurpassed graphic detail quality
- Compliment play equipment using new and engaging activities

Please contact your distributor for additional designs or visit playguardsurfacing.com.



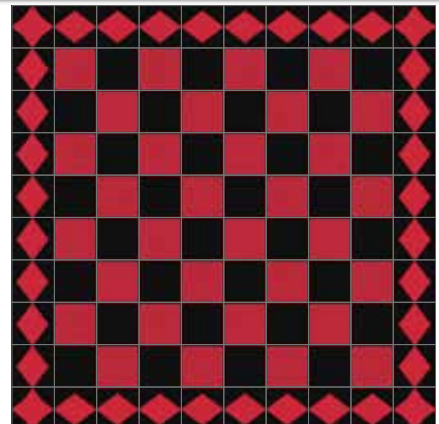
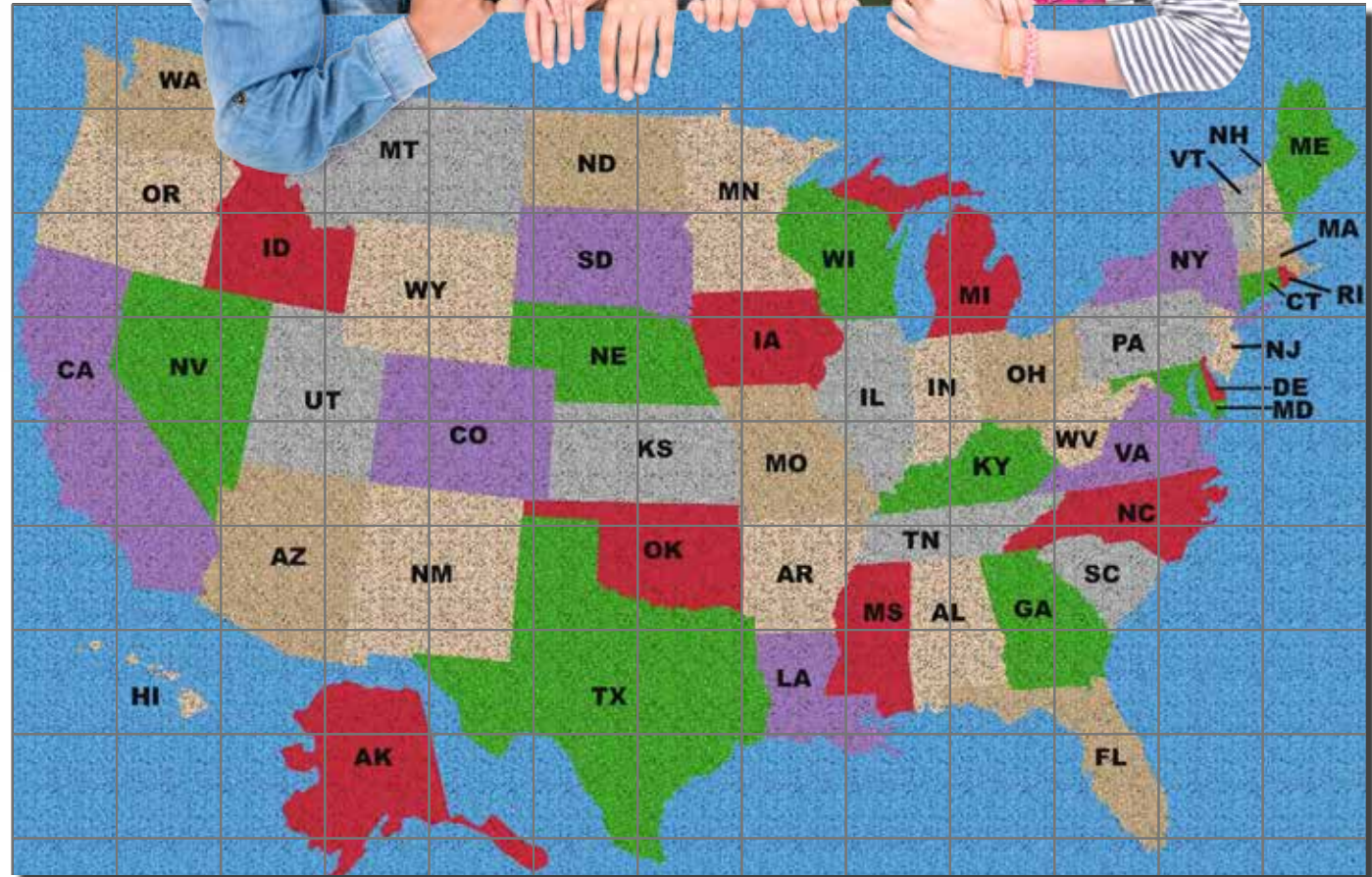

Quad Blok™

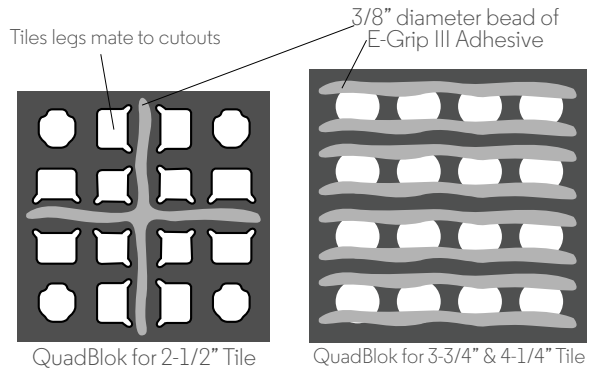

NOTE: ONE QUAD BLOK PER TILE IS REQUIRED

Property	Test Method	Typical Result
Density	ASTM D297	45-lbs./cu.ft. ³ min.
Tensile Strength	ASTM D412, DIE C	100psi. min.
Elongation	ASTM D412, DIE C	65% min.
Compression	ASTM F36	Recovery
@50psi	15%	80%
@100psi	28%	90%
@200psi	45%	95%
Shore A Hardness	ASTM D2240	50 +/- 5 points
Tear Strength	ADTM D624, DIE C	30-lbs.f/in
Flexibility	ASTM F147	0-1 Factor
Compression Set B 25% deflection, 22 hrs. 158°F	ASTM D395	25%
Compression Set (Foam) 50% deflection, 22 hrs. 158°F	ASTM D3676	20%

Features:

- Available in 2 sizes:
 - 8" x 8" x 17mm for 2-1/2" Tiles
 - 8.75" x 8.75" x 19mm for 3¾" and 4¼" tiles
- 15 year warranty
- Recycled rubber and polyurethane composition
- Highly durable
- Enables rooftop installation capabilities
- Eliminates damage to the roofing membrane
- Allows rapid water drainage around each tile
- Ample void under tiles for water drainage flow

Ideal for playgrounds, rooftops, and patios, our exclusive Quad Blok™ system offers reliable easy-down/easy-up installations. Quad Blok connectors are made of high quality, post-consumer tire rubber and polyurethane. Unlike labor intensive poured-in-place systems, Quad Blok modular connectors feature precisely located multiple openings that interface with the corner leg understructure of PlayGuard tiles. These connectors are quick and easy to use without adhering to or causing damage to playground substrates. If an individual tile ever does need replacement, removing and securing a new tile causes minimal disruption or downtime.



Rooftops & Patios



PlayGuard Safety Surfacing is ideal for rooftop and patio applications due to its unique Quad Blok installation system and cushioned resilience. With the Quad Blok system, PlayGuard tiles are attached to the connector and not the roof itself. This eliminates costly damage to elastomeric membranes and ensures that the quality of the roof remains unaltered. ColorMill® EPDM allows for greater UV fade resistance compared to other EPDM rooftop and patio applications.

PlayGuard tiles also allow for water drainage. The superior design of PlayGuard, in combination with the connector system, ensures that water will quickly reach the roof surface and flow to drains, avoiding ponding and enabling easy maintenance. The tiles' superior durability and non-slip properties make them ideal for areas prone to direct exposure to the natural elements and, with the Quad Blok installation system, damaged tiles can be easily removed or replaced.



Technical Specifications

Critical Fall Height and Physical Dimensions

Thickness	Weight (lbs.) Each (Not less than)		Critical Fall Height (ft.)	
	Pigmented	Carnival & Safari	Pigmented	Carnival & Safari
1"	16	16	2.0	2.0
2-1/2"	25	27	6.0	6.0
3-3/4"	34	N/A	8.0	N/A
4-1/4"	N/A	39	N/A	8.0
2-1/2 & 2-1/8" Polyfoam	27	29	10.0	10.0

Packaging Information

Full Pallet Weight (lbs.)

Thickness	Pieces/Pallet	Pigmented	Carnival & Safari	Pallet Height	Other Packaging Information
1"	120	1,980	1,980	35.00"	Standard Pallet Size: 48"x48" Empty Pallet Weight: 60 lbs Standard Pallets in 48' Van: 20
2-1/2"	100	2,560	2,760	66.00"	
3-3/4"	60	2,100	N/A	62.00"	
4-1/4"	60	N/A	2,400	68.00"	
2-1/8" x 4' x 6' (Polyfoam Sheet)	23	680	680	52.00"	

Physical Data Test

Characteristic	Test Method	Pigmented Tile	Carnival & Safari Tile
Density	ASTM D297	50 lb./ft ³ min.	70 lb./ft ³ min.
Tensile Strength*	ASTM D412, DIE C	150 lb./in ² min.	180 lb./in ² min.
Elongation at Break*	ASTM D412, DIE C	50% min.	70% min.
Abrasion Test*	ASTM D3389	Less than 0.010" lost	Less than 0.010" lost
Coefficient of Friction*	ASTM D2047	0.8 min.	0.8 min.
Flammability	ASTM D2859 (Burning Pill Test)	8 of 8 samples passed	8 of 8 samples passed
Wheel Chair Accessibility	ASTM F1951-08	Pass	Pass
Lead Content	US EPA Method 3052:1996	Pass	Pass

FIFTEEN YEAR LIMITED WARRANTY INFORMATION - Materials, Workmanship, and Performance

Number of years from date of original installation to date of claim	Percentage of product purchase price found to be defective or non-compliant
0-6	100%
More than 6, but less than 7	60%
More than 7, but less than 8	40%
More than 8, but less than 9	30%
More than 9, but less than 10	20%
More than 10, but less than 12	10%
More than 12, but less than 15	5%

PLAYGUARD[®]

SAFETY SURFACING



PlayGuard is manufactured by Ecore. Since 1871, Ecore has been transforming reclaimed waste into unique surfaces that make people's lives better. What started with simple cork closures has evolved into a diverse portfolio of products solving complex problems in applications ranging from playgrounds, weight rooms, and turf fields to hospitals, hotels, and retail environments. We are driven everyday by a simple question, "Can a floor do more?" At Ecore, we believe the answer is "YES." We are building our company and the products we offer based on the simple notion that surfaces should elevate beyond current expectations. Our energy is focused on the interaction between people and the surface. We engineer performance well beyond industry standards related to acoustics, ergonomics, and safety. Harvesting the unique power from a myriad of waste streams, Ecore creates products that align—substantial force reduction with a balanced amount of energy return to create dynamic surfaces that are catered to the individual and the application.



Distributed by: **ACM Playgrounds, Inc.**
 157 1/2 Seward St., Buchanan, NY 10511
 T. 914-739-6858 - F. 914-736-0554

www.acmplaygrounds.com

**PlayGuard is FloorScore
 Certified for Indoor Use**



by **SCS**certified.

This product has been certified to meet the requirements of the flooring products certification program for indoor air quality.

AS CERTIFIED BY



CERT. #

SCS-FS-01793

Ecore reserves the right to make updates to this catalog at any time. For the most updated version, or for more information, please visit playguardsurfacing.com or call 800.851.4746.

